

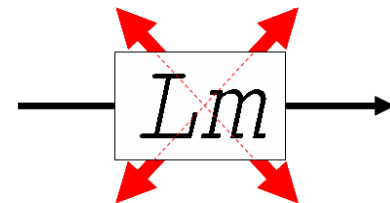

Interagency Retail *Listeria monocytogenes* Risk Assessment

Data Sources, Data Review,
and Data Gaps

- Régis POUILLOT – CFSAN/FDA/HHS
June 23, 2009



Outline

- What are the Data Needs?
 - Request for data and information: Federal Register notices
- Why?
 - Cross-Contamination
 - Data needs, Data sources, Data review, Data Gap
 - Bacterial Growth
 - Data needs, Data sources, Data review, Data Gap
 - Cleaning and Sanitizing
 - Data needs, Data sources, Data review, Data Gap

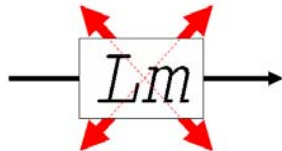

Federal Register Notices

DEPARTMENT OF HEALTH AND HUMAN SERVICES

Food and Drug Administration

[Docket No. FDA-2008-N-0658]

Risk Assessment of the Public Health Impact From Foodborne *Listeria monocytogenes* In Some Ready-to-Eat Foods Sliced, Prepared, and/or Packaged in Retail Facilities; Request for Comments and for Scientific Data and Information

AGENCY: Food and Drug Administration, HHS.

ACTION: Notice; request for comments and for scientific data and information.

DEPARTMENT OF AGRICULTURE

Food Safety and Inspection Service

[Docket No. FSIS-2009-0012]

DEPARTMENT OF HEALTH AND HUMAN SERVICES

Food and Drug Administration

[Docket No. FDA-2008-N-0658]

Interagency Retail *Listeria monocytogenes* Risk Assessment: Notice of a Public Meeting

AGENCIES: Food Safety and Inspection Service, USDA; Center for Food Safety and Applied Nutrition, Food and Drug Administration, DHHS.

ACTION: Notice of public meeting.

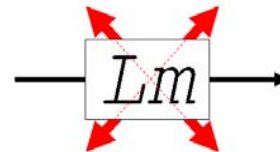

Request for data (1/4)

- **Characteristics of RTE food markets** in the United States, including:
 - Volumes of cheeses, deli-type salads and deli meats sliced/prepared by manufacturers and the volumes sliced/prepared in retail facilities
- **Characteristics of deli departments in groceries**, including the proportion of separated seafood/meat/dairy deli departments in groceries.

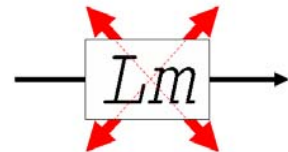

Request for data (2/4)

- ***Listeria monocytogenes* (Lm) levels and/or frequencies in products**
 - arriving at retail facilities and
 - sold by retail facilities.
- **Factors that influence the growth of *Listeria monocytogenes* in cheeses, deli meats, and deli-type salads, including:**
 - Growth rates of *Listeria monocytogenes*,
 - Chemical characteristics of cheeses, deli meats, and deli-type salads,
 - Proportions of deli meats treated with growth inhibitors, the inhibitors used, the level of growth inhibitors, and their efficiency;
 - Data on the temperatures to which cheeses, deli meats, and deli-type salads are exposed at retail.

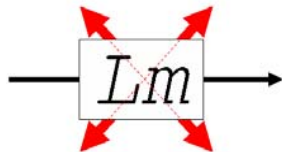

Request for data (3/4)

- **Environmental contamination** data, including:
 - Data and information on the **prevalence and levels of *Lm* in the retail environment**;
 - Data on the **growth of *Lm* on non-food surfaces** including environmental biofilm growth.
- **Factors that influence the environmental contamination and the cross-contamination of food by *Listeria monocytogenes* in retail facilities**, including:
 - Data and information on the **potential transfer of *Lm* to food from the retail environment**, e.g., experimental studies on the transfer to food from drains, slicers, food contact surfaces, and non-food contact surfaces; and
 - Data and information on **food handlers' activities**, e.g., observations of food handlers' practices and monitoring of specific food safety actions in retail facilities.



Request for data (4/4)

- **Identity and effectiveness of control measures or interventions intended to reduce levels and frequency of Lm in the retail environment, including:**
 - Environmental sanitation procedures including the sanitizers and protocols used, frequency of application, and efficiency; and
 - Worker sanitation procedures including frequencies, protocols, and efficiency.
 - Any other data related to the occurrence, growth, and control of *Listeria monocytogenes* in retail facilities
- Very wide areas...

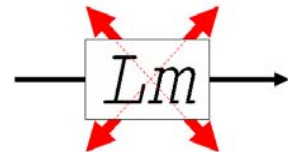

Major Data needs

- Factors that Impacts the Final Contamination
 - Initial Contamination in Products
 - Cross-Contamination
 - Bacterial Growth
 - Cleaning and Sanitizing

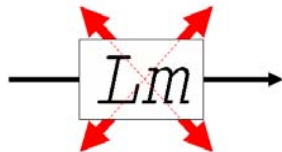

Cross-Contamination (transfer of *Listeria monocytogenes*)

預防交互污染
**Prevent
cross-contamination**

- 在處理食物之前及處理生肉之後，要洗手
- 每次在處理肉類禽類之後，或在預備不同種類食物之間，要將用過的砧板，菜刀，匙筷，檯面等擦洗，沖淨及消毒。
- 將生肉貯放在熟食或即可食用的食物之下，或另放他處。



當細菌由食物、人手、用具等傳到其他食物，就是交互污染。

Developed by Snohomish Public Health District & Isabella-Kang County Department of Public Health
Seattle - King County Department of Public Health

CHINESE-2
©2004 Pacific Health Alert
Prevention & Control
King County Department of Public Health

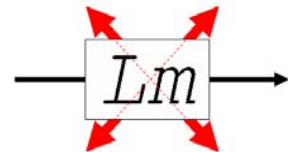

Needed Data? One Cross-Contamination.

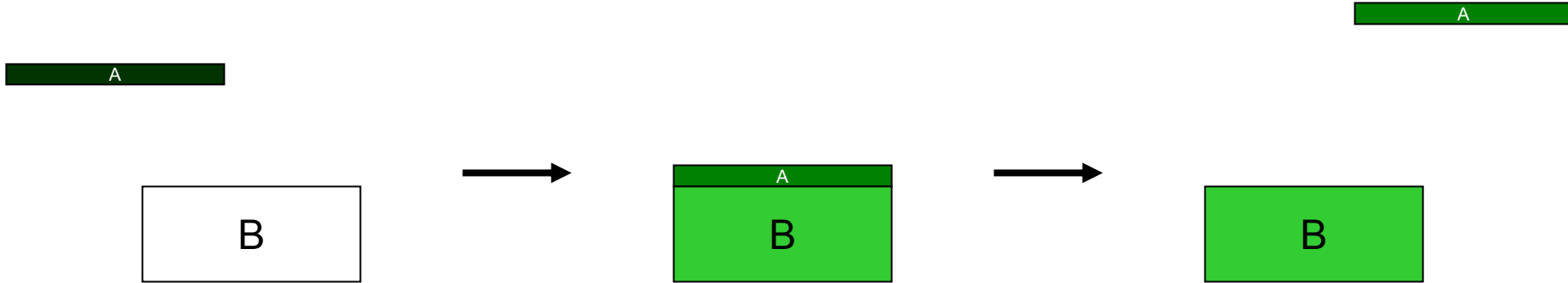

- Initial contamination of A
- Transfer coefficient from A to B
 - Proportion of bacteria that shifts from A to B
 - Published literature

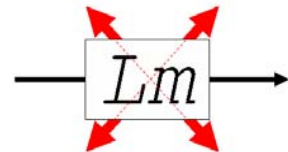

Transfer Coefficient Studies

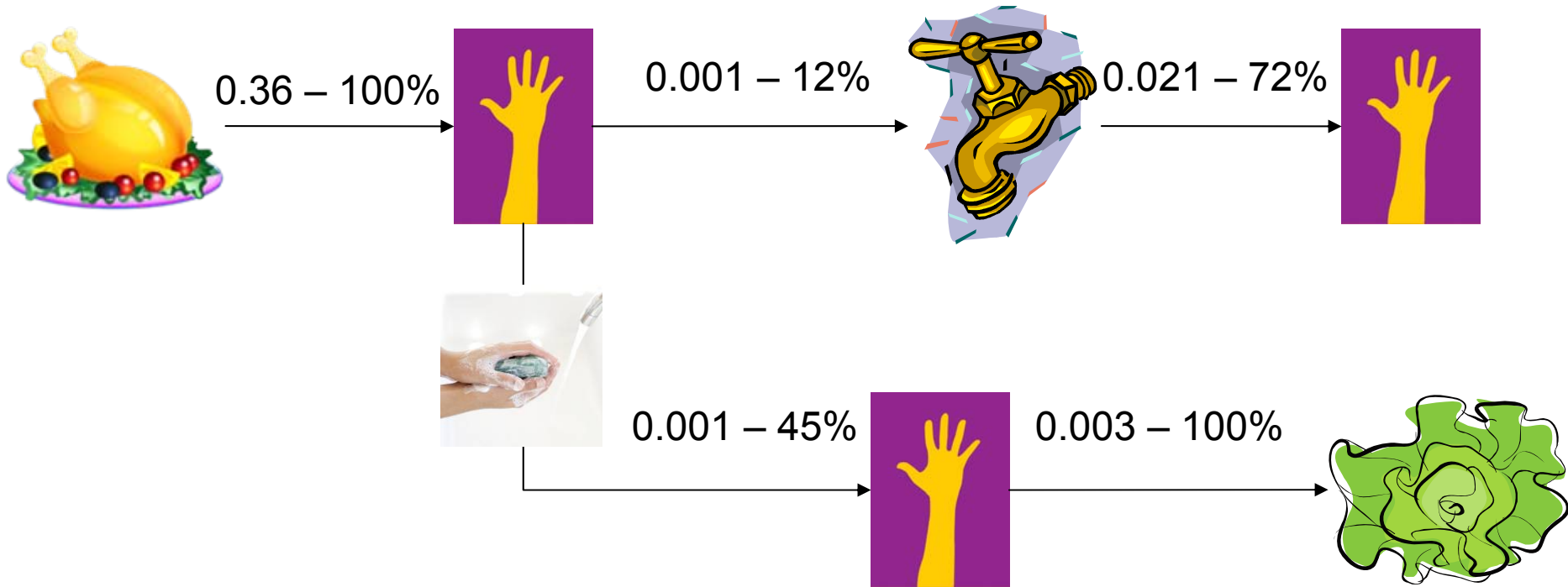

Example: Chen *et al.*, 2001

10^8 *Enterobacter aerogenes* → skinless chicken breast meat
A participant cut the meat → handle a faucet → wash hands
→ cut a lettuce

Bacterial count on the hands, the faucet, the lettuce

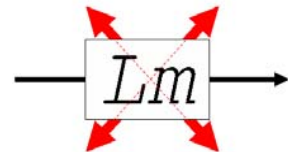

Literature Review

- Currently > 900 transfer coefficients from 20 references
- Issue: huge variability
 - Source, Recipient, Contact, Bacteria, ...
 - e.g. transfer coefficients from meat → stainless steel surface

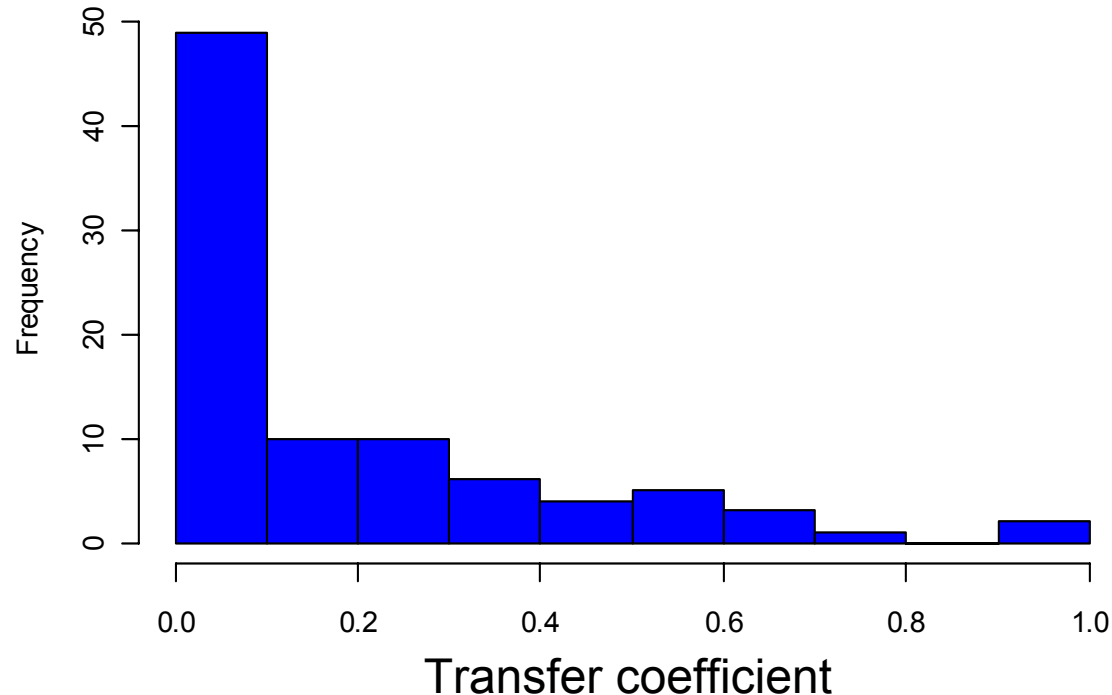

A Special Case: the Slicer

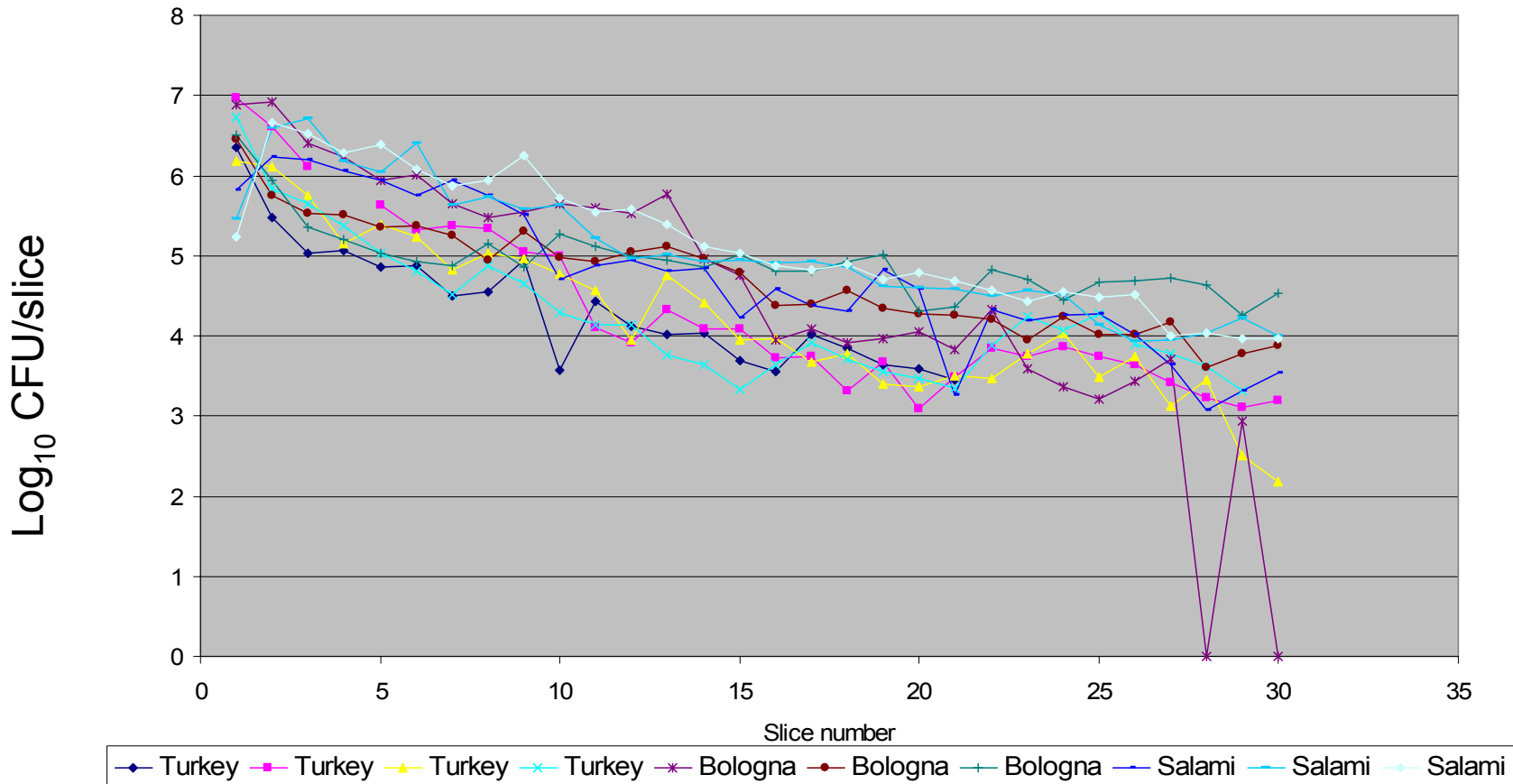

Transfer of *L. monocytogenes* from an inoculated slicer blade (10⁸ CFU/blade) to uninoculated turkey, salami and bologna. (Vorst *et al.*, 2006)



Multiple Cross-Contaminations

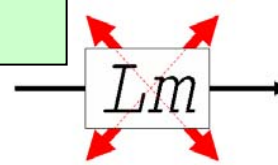
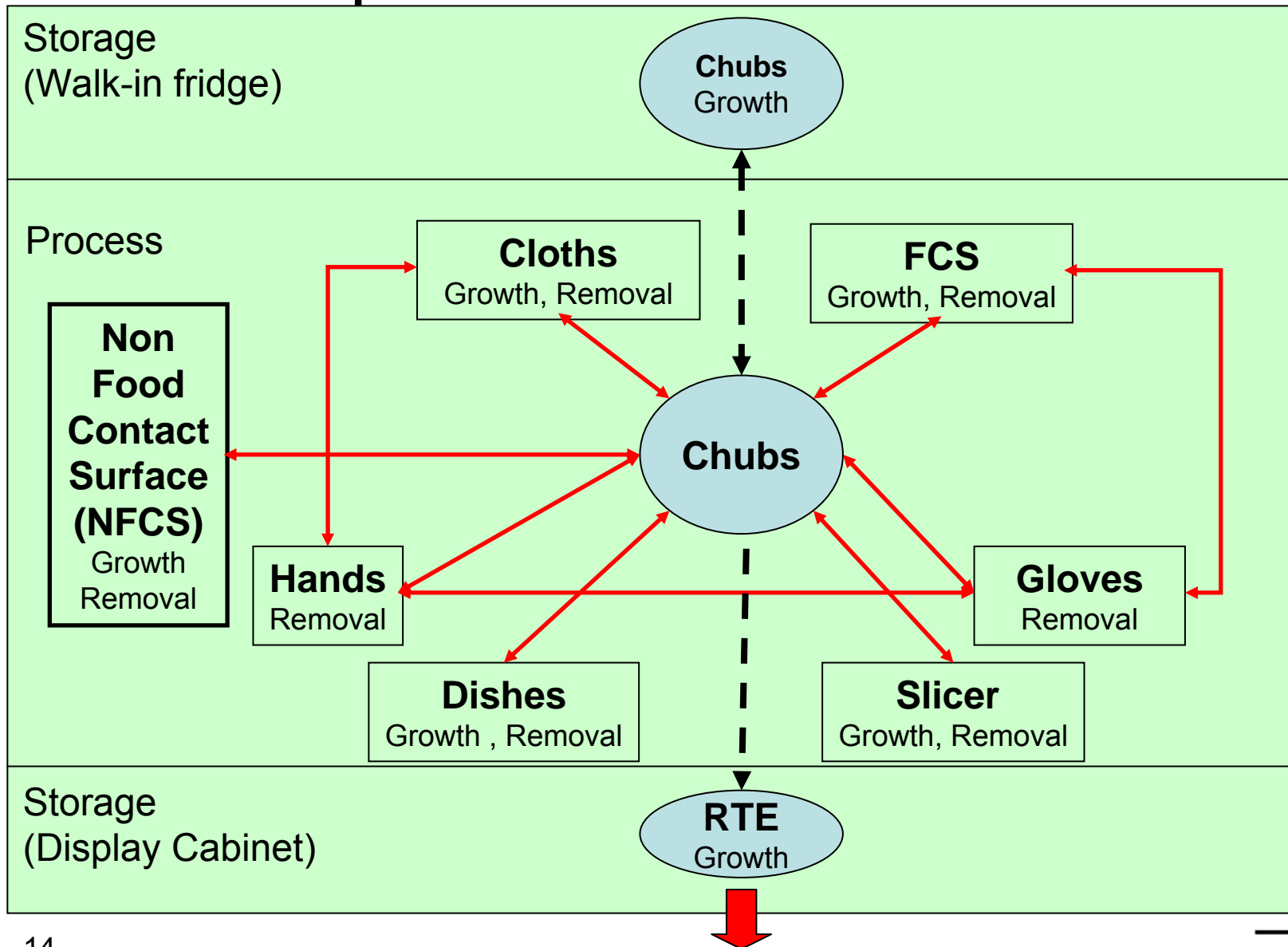

Additional Data Needed

- **Frequency / Probability of Contact between Objects**

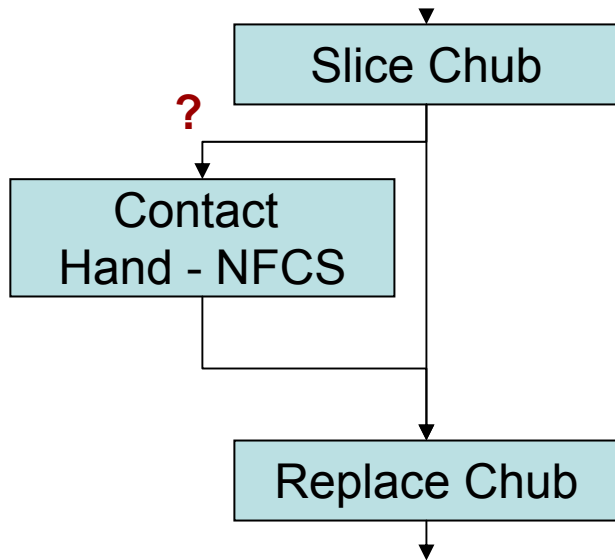

How frequent is a contact
Hand - Non Food Contact Surface (NFCS)?

After a contact Hand - NFCS, what is the probability that the food worker changes his gloves?

Before changing his gloves: What is the probability that he also washes his hands? ...

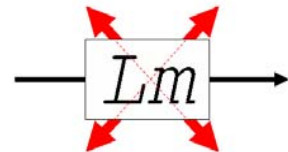

Pilot Observational Study

- In 9 retail facilities: observation of food worker behaviors

STORE 103 P 498			
Time	Action Number	Code	Translation
11:20	1	OPN CAS US GLV	Open deli case using gloved hands
	2	PUP HM	Pick up ham
	3	CLS CAS	Close deli case
	4	UWP HM	Unwrap ham
	5	P HM ON SLI #1	Put ham on slicer #1
	6	TCH KN	Touch knob
	7	SL HM ON SLI #1 onto GLV	Slice ham on slicer #1 onto gloved hands
	8	P SLD HM ON BTM OF SLI#1	Put sliced ham on bottom of SLI#1
	9	SL ONTO GLV	Slice onto gloved hands
	10	P SLD HM ON BTM OF SLI#1	Put sliced ham ON bottom of SLI#1
	11	PT DT ON SCL #2	put deli tissue on scale #2
	12	WE SLD HM	weigh sliced ham
	13	SL HM ON SLI #1 onto GLV	Slice ham on slicer #1 onto gloved hands

- First results: very standard practices | food worker
- Once ‘scaled’ on a realistic value, the sensitivity of the output to this parameter may be tested → Objectives for a more complete study

“Collaboration and/or supported by JIFSAN, UM, FDA, FMI”



Cross-Contamination: Remaining Data Gap

- Probability and level of transfer from / to the **Niche**
- Data: AFDO study, Cornell's data, ... but
 - Questions remain, e.g.:
 - Drains → origin or indicators of contamination?
 - Cart wheels → origin or indicators of contamination?
 - Quantification?

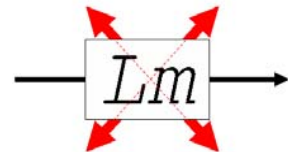
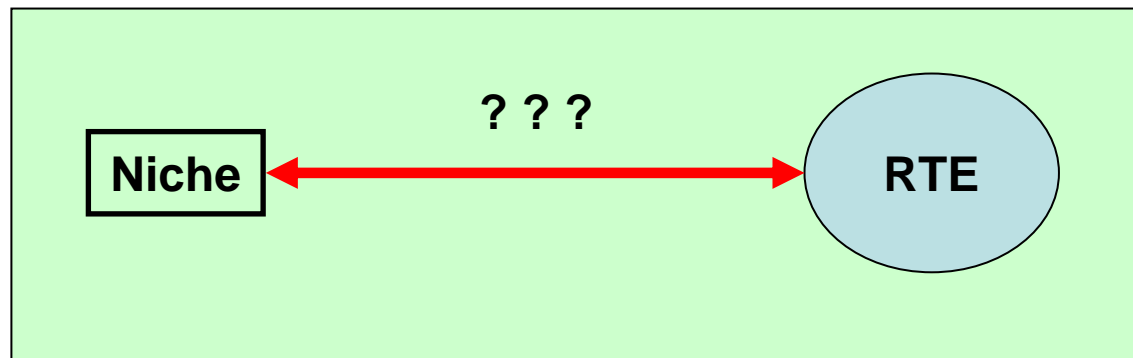

Growth

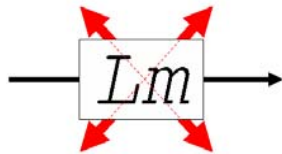
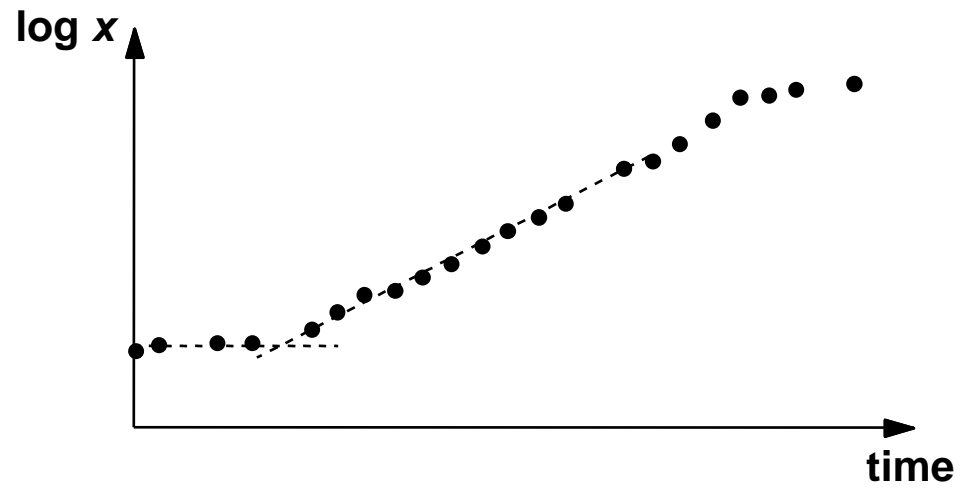

Listeria monocytogenes Growth

- The result of bacterial growth may be an increase of a few bacteria to 10,000,000 bacteria per gram of product in few days
- Bacterial growth is a function of:
 - Time
 - Environment
 - Temperature, pH, water activity,
 - Bacteria Characteristics
 - Strain
- Characteristics of *Listeria monocytogenes* Growth
 - Growth may occur at
 - Low temperature: even between 29°F - 40°F (but at a low rate)
 - (Relatively) low and high pH: from 4.5 to 9.6
- Note: an increasing proportion of products with antimicrobial growth factors

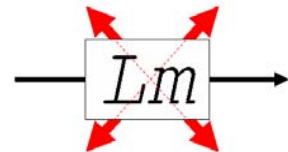

Predictive Microbiology Model

- Use of mathematical models to predict the growth of bacteria over time under certain conditions
- Huge improvements in the models in the last 20 years
 - Interactions between parameters,
 - Low concentrations,
 - Lag phase,
 - Varying environment,
 - Growth - no Growth interface...

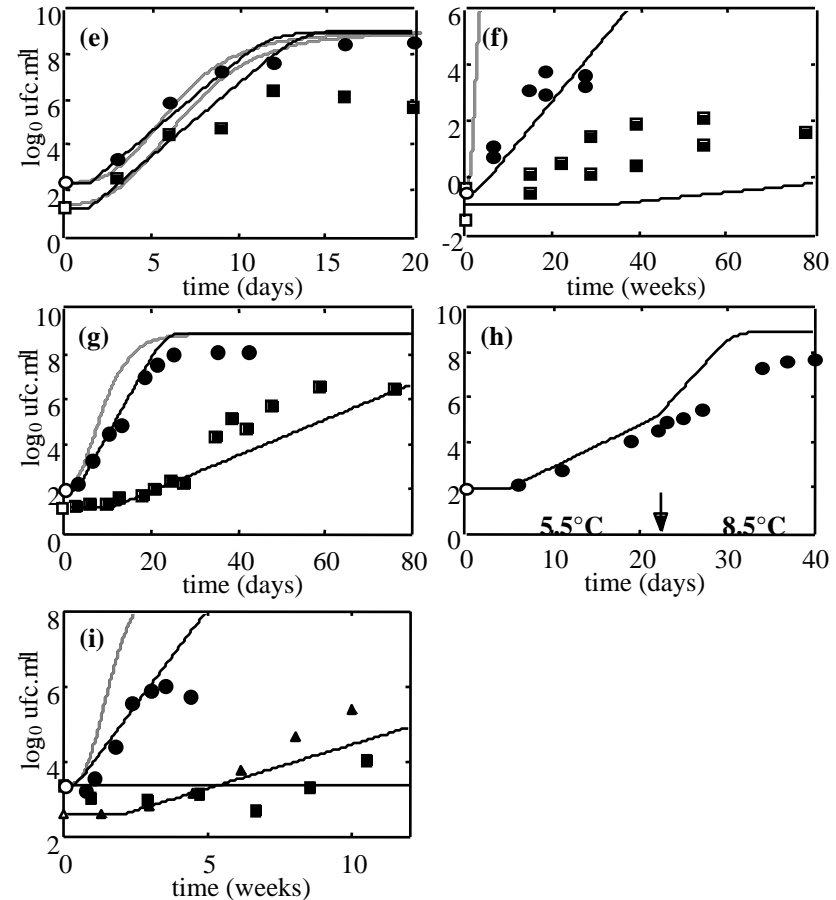

Sources of Growth Data

- Growth Rates specifically acquired in the products
 - Published Literature ++
 - Response to FR notice
- Characteristics of the products
 - pH, water activity, antimicrobial growth factors
 - Published Literature --
 - Response to FR notice
- Storage Temperature at retail
 - Cold room, Display cabinet
 - Food Code (baseline)
 - Ecosure 2008 study
 - NAFSS study
- Storage Duration at retail
 - Food Code (baseline)



Cleaning and sanitizing procedures

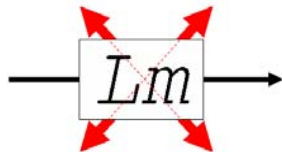

Needed data? One Cleaning.

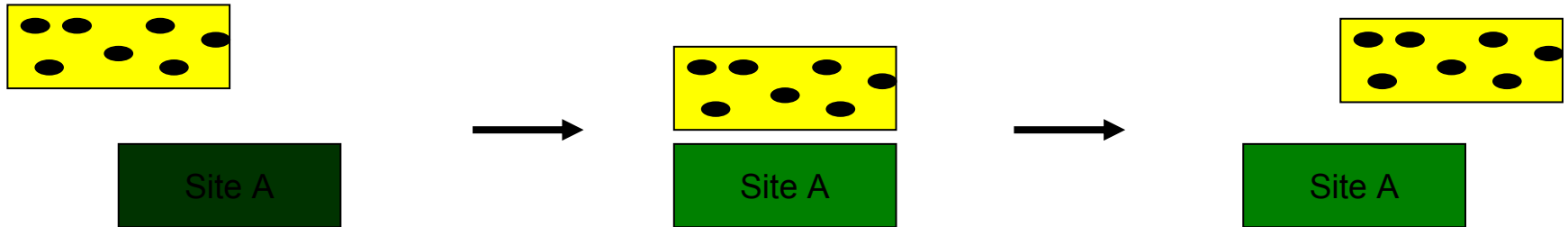

- Initial contamination of A
- Reduction in the number of bacteria during the cleaning / disinfection
 - Published Literature

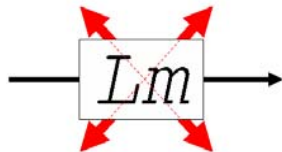

Log reduction: numerous studies

- Example: Best *et al.*, 1990

Antimicrobial compound	Log ₁₀ reduction in cfu/cm ²	
	Bacteria in Suspension	Bacteria dried on stainless steel
Ethanol	5 - 6	3 - 4
<i>Sodium hypochlorite</i> (60 µg/ml available chloride)		5 - 6
<i>Sodium hypochlorite</i> (10 µg/ml)	>6	1 - 2
<i>Sodium dichloroisocyanurate</i> (60 µg/ml)		4 - 5
<i>Sodium dichloroisocyanurate</i> (10 µg/ml)	5 - 6	<1
Chloramine -T	3 - 4	1 - 2
Sodium hypochlorite with 5% methylethanol	>6	3 - 4
...

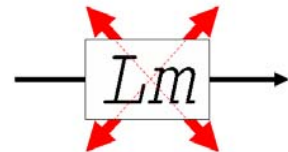

Data Sources

- Product used
 - Food Code (baseline)
 - Literature review
 - Observational study
 - Response to FR notice
- Frequency of cleaning operations (from “wipe out” to “complete cleaning”)
 - Food Code (baseline)
 - Literature review
 - Observational study
 - Response to FR notice
- Protocol (e.g. Duration)
 - Food Code (baseline)
 - Literature review
 - Observational study
 - Response to FR notice

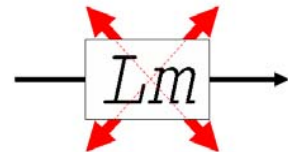

From the Retail to the Risk

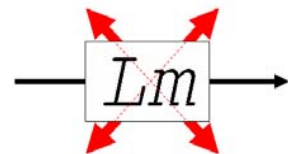

From the Retail to the Risk

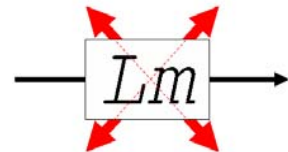
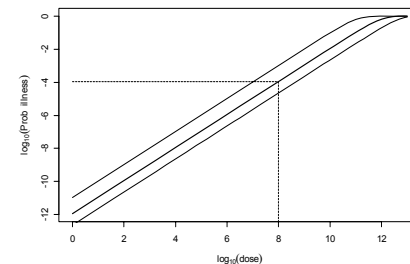
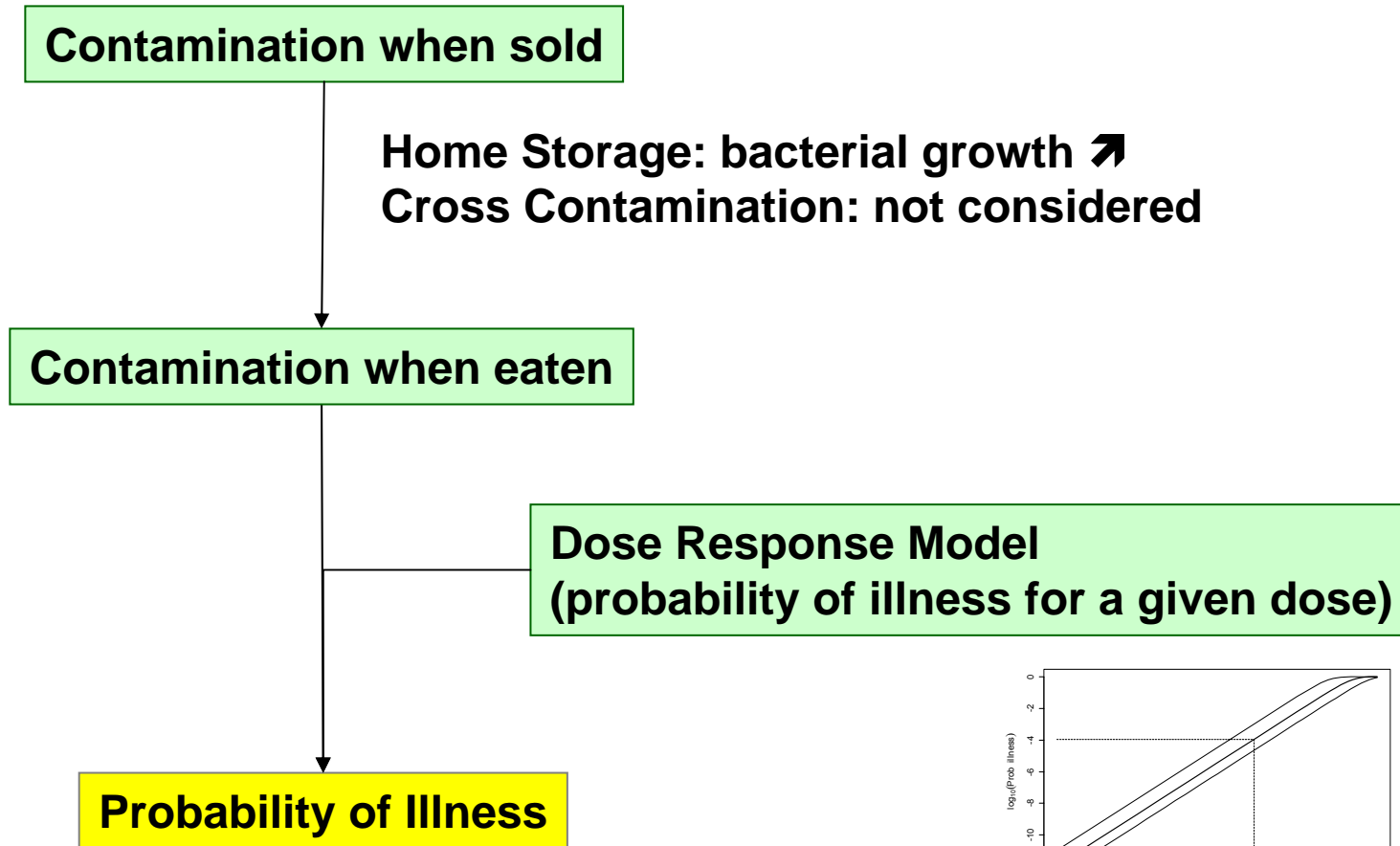

Transport and Home Storage

- *Listeria monocytogenes*
Growth → Predictive
Microbiology Models
- Transport
 - Ecosure 2008
- Home Storage
 - Temperature: RTI 2007 and
Ecosure 2008 studies
 - Time: RTI 2007 study

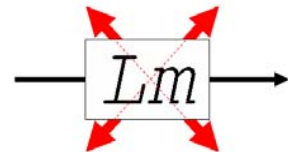
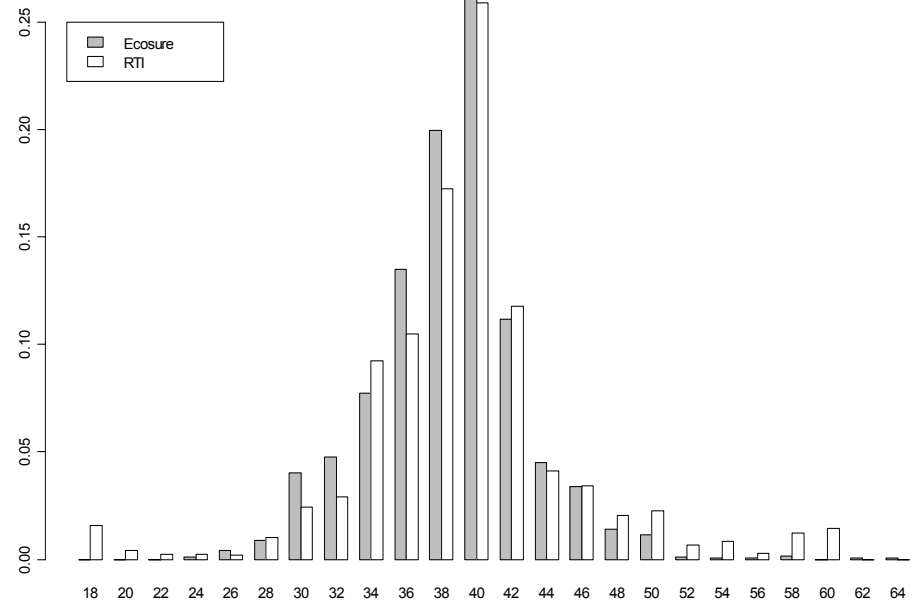

Conclusions

- Some data are available but not all the needed data
- Two dockets opened for comments and data until September 29th
 - www.regulations.gov
 - **Docket No. FDA-2008-N0658**
 - **Docket No. FSIS-2009-0012**
- Some data gap will hardly be filled
 - Probability / level of transfer Niche ↔ Product

→ Limitations of the model

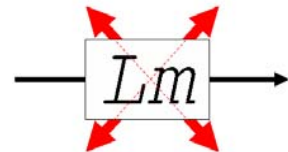

Thanks for your attention

- Project supported in part by an appointment to the Research Participation Program at the CFSAN administered by the Oak Ridge Institute for Science and Education through an interagency agreement between the U.S. Department of Energy and the U.S. FDA.

